

Window Security Screens

Installation
Instructions

Ford Full Size Van , GM Full Size Van, and Sprinter

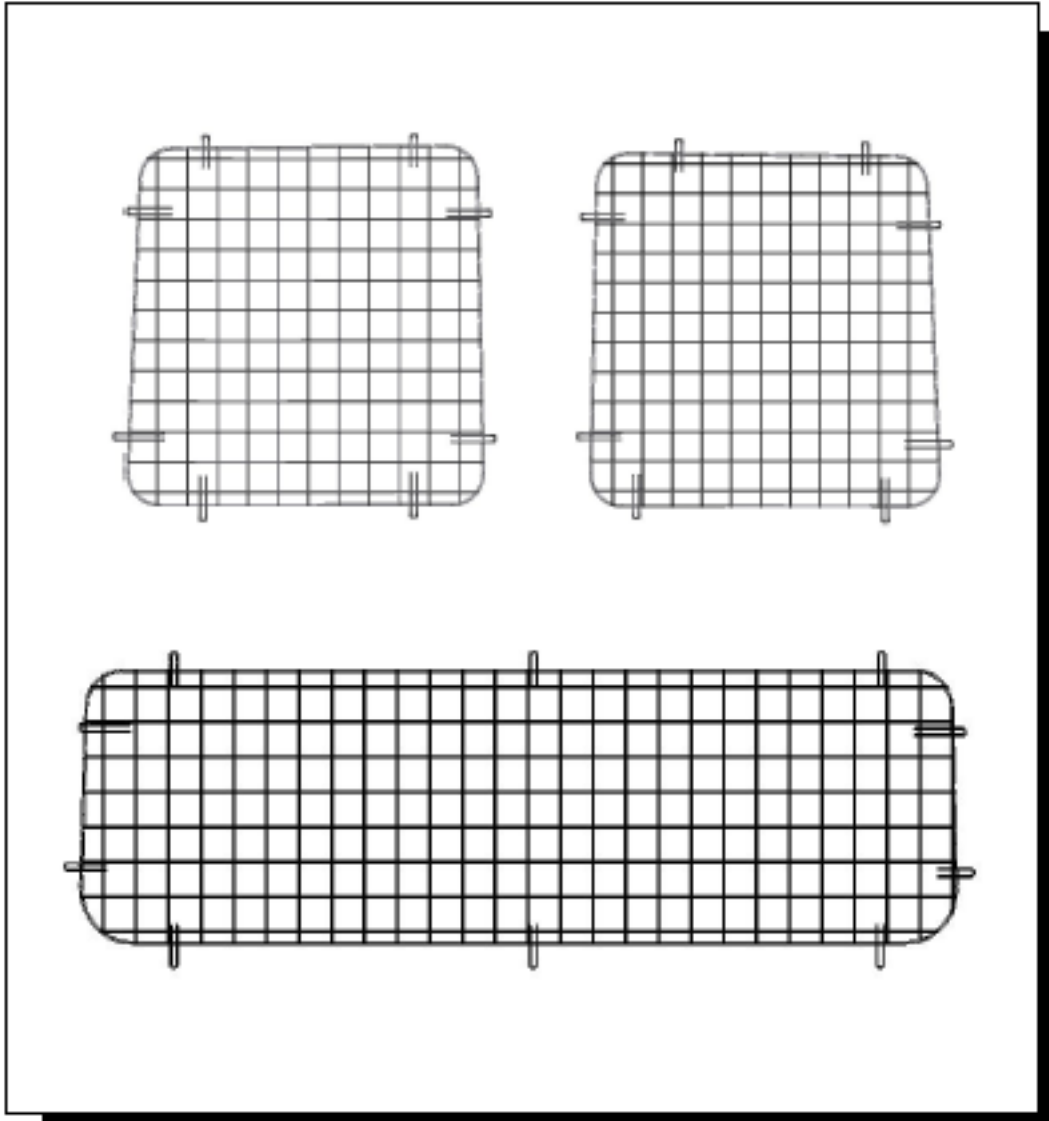

For Part Numbers:

027589, 027590, 027591, 027592, 027593, 027594, 027597, 027598

Required Tools :

7/16" Wrench or Socket
1/8" and 3/16" Drill Bits
Drill Motor

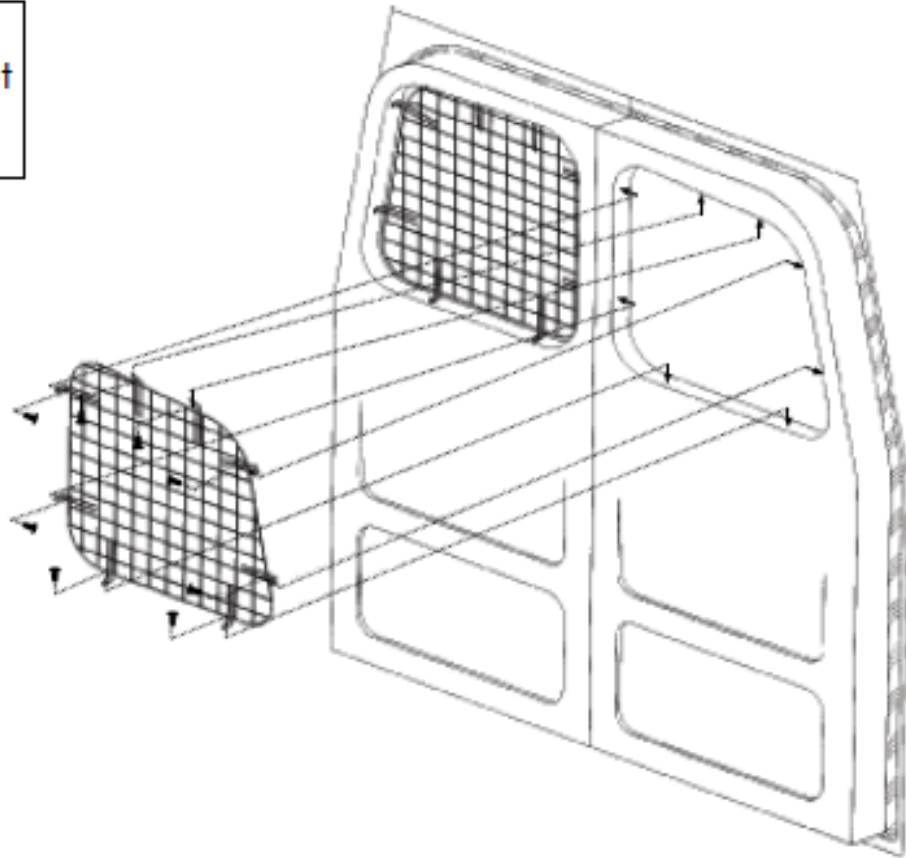

Installation Instructions:

Begin by verifying that the window guards (screens) agree with your application.

1. Push screen inside window opening.
2. While holding the screen firmly in the window opening, mark through each top attachment loop.
3. Drill a 1/8" pilot hole at each mark then drill out each 1/8" pilot hole to 3/16".
4. Attach screen to the window opening using #14 x 1" sheet metal screws.
5. Press the screen against the inside bottom of the window opening and mark through each bottom attachment loop.

Note: Sliding side door screens do not have bottom loops, skip to Step 7.

6. Repeat Steps 3 and 4.
7. Press each side of the screen against the window opening and mark through each side attachment loop.
8. Repeat Steps 3 and 4 to complete the installation.
9. Repeat Steps 1 through 8 for other door.

3 Year / 36,000 Mile Limited Warranty

MASTERACK® commercial van and pickup equipment is warranted to be from defects in material and workmanship, under normal use and service for a period of one (1) year from date of purchase. Factory installations, and products installed in new vehicles by an authorized MASTERACK® installer are warranted for (3) years or 36,000 miles (60,000 KM), whichever comes first. **This warranty covers only repairs, or at MASTERACKS' discretion, replacement to correct any defects related to materials and workmanship.**

This warranty does not apply to:

- Additions, alterations, or installations made by persons including dealers, other than MASTERACK® and its authorized distributors, made in accordance with MASTERACK® specifications and / or instructions, nor to defects arising out of attribute to such additions, alterations or installations.
- Defects attributable to abuse or misuse of the product, misapplication, negligent accident, modification or tampering.
- Damage resulting from failure to promptly notify and comply with the instructions of the dealer or manufacturer about defects when noted.
- Any incidental or consequential damages connected with a defect, either while under warranty or afterward, including the cost of a rental truck and / or loss or revenue.

THE WARRANTY IS THE ONLY WARRANTY APPLICABLE TO A MASTERACK PRODUCT PURCHASE. ALL OTHER WARRANTIES, EXPRESSED OR IMPLIED, INCLUDING BUT NOT LIMITED TO, THE IMPLIED WARRANTIES OR MERCHANTABILITY AND FITNESS FOR A PARTICULAR PURPOSE ARE DISCLAIMED. MASTERACK® AND ITS SUBSIDIARIES, SHALL NOT BE LIABLE FOR ANY INCIDENTAL OR CONSEQUENTIAL DAMAGES ARISING OUT OF ANY BREACH OF THIS WARRANTY, NOR SHALL THE DAMAGES EXCEED THE RETURN AMOUNT OF THE PURCHASE PRICE PAID BY THE ORIGINAL PURCHASER.

Warranty claims must be submitted to either your sales representative or a customer service representative at **1-800-222-8785**. The vehicle must be delivered to the original MASTERACK® authorized dealer for inspection and any warranty service. Any warranty service to be performed by a source other than MASTERACK® location or an approved MASTERACK® distributor must be authorized in advance of the repairs by the MASTERACK® Warranty Administrator and a purchase order issued by MASTERACK® in advance or repairs for the authorized repairs.