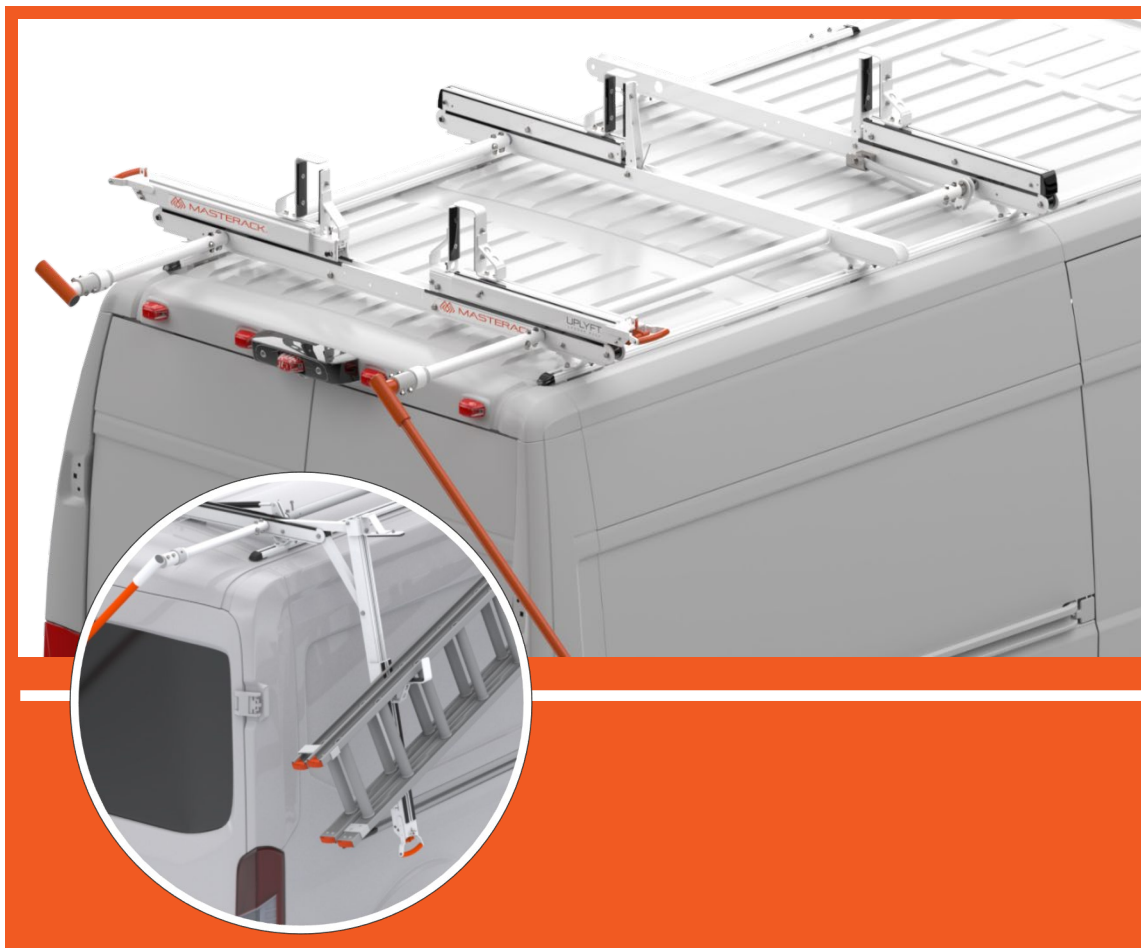
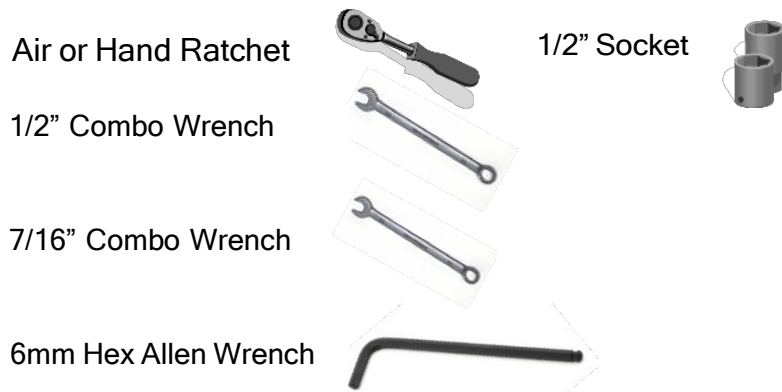

RAM PROMASTER 3RD CROSSBOW LADDER RACK (02T033KP)
Recommended Tools

PN	DESCRIPTION	QTY
02P675	CROSSBOW ASSY - REAR	1
02P326	CROSSBOW ASSY FRONT UPLYFT	1
02R122	CROSSBOW ASSY 3RD UPLYFT	1
02P328	CONNECTING TUBE UPLYFT	1
02T035	CONNECTING TUBE 3RD CB PM	1
02P103	DROP DOWN ASSY UPLYFT	2
02P393	MIDROOF HANDLE ASSEMBLY	1
02P663	LADDER STOP ASSY FRONT	2
02P664	LADDER STOP ASSY REAR	2
02P665	ROTATION ASSEMBLY MR	2
02P655	FLIP STOP ASSY UPLYFT	2
02P666	HARDWARE BAG UPLYFT	1
02P788	MOUNTING RAIL- PWDRCOAT	4
02P148	RAIL CAP UPLYFT	4
02T044	HARDWARE BAG 3RD CB PM	1
02T062	SHIP PK UPLYDT 3 RD CRSBW PM	1

UPLYFT™ LADDER RACK SYSTEM

Before installation, review this document to ensure that all parts and hardware are included in the package.
 In the event that parts are missing, please contact Masterack at 1-800-222-8785 to re-order missing parts.

BEFORE INSTALLATION, PLEASE REVIEW THIS ENTIRE DOCUMENT, UNTIL YOU ARE COMPLETELY FAMILIAR WITH ALL STEPS BEFORE BEGINNING. A "PRACTICE RUN" OF THESE STEPS/PROCEDURES MAY BE HELPFUL TO ASSIST YOU IN FAMILIARIZING YOURSELF THOROUGHLY AND AVOID COSTLY ERRORS.

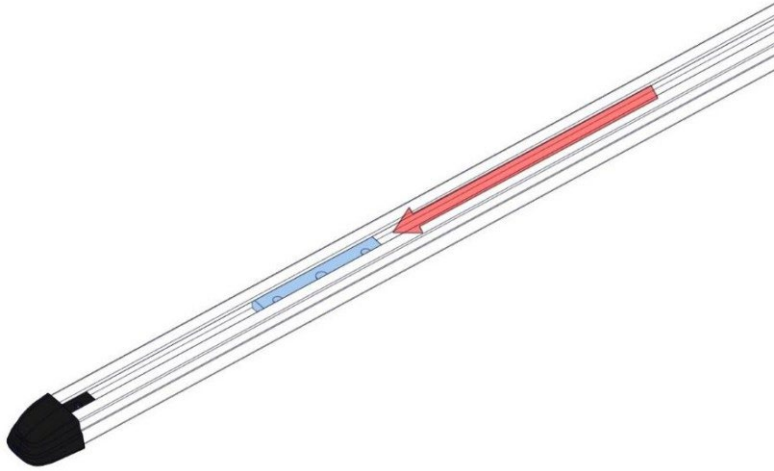
**Step 1.**

Slide receiver block (02P118) into both mounting rails (02P788)

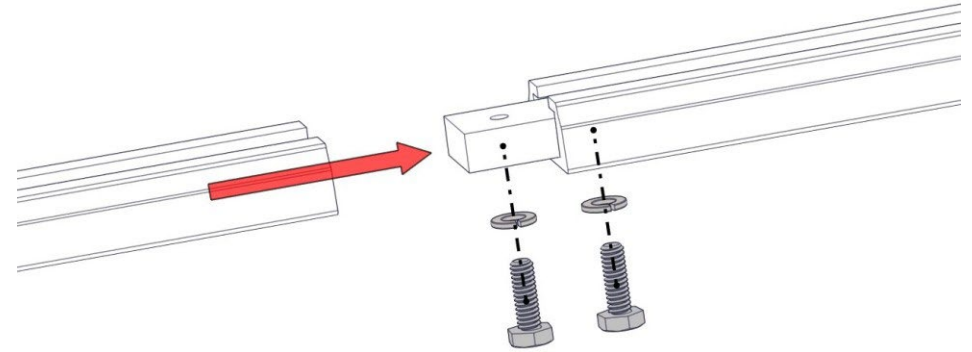
**Step 2.**

Slide joining block (02P125) into channels. Fasten with 1/4" lock washers and 1/4" X 1" hex bolts. Tighten with 7/16" wrench.

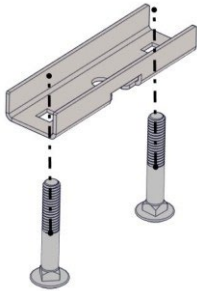
**Step 3.**

Install 2 of the Carriage Bolts 5/16" x 2" bolts into base bracket (repeat 6 times).

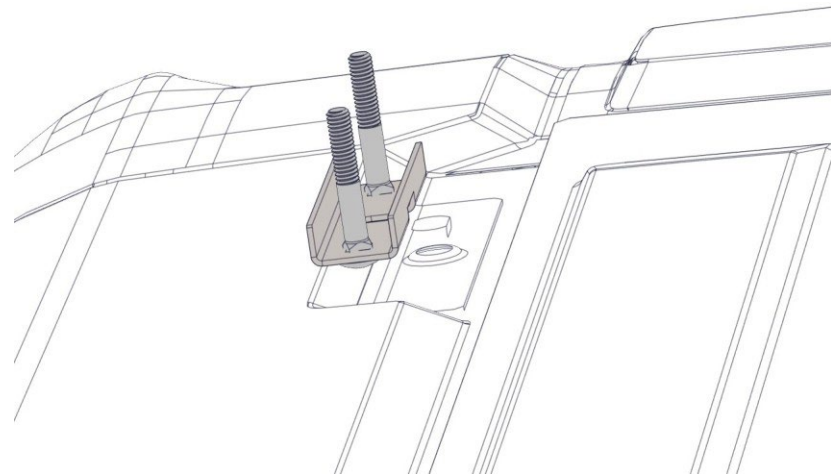
**Step 4.**

Install base brackets on vehicle by locating mounting tabs on top of vehicle. Pull tabs up and slide the bracket underneath. Repeat for all 6 locations.

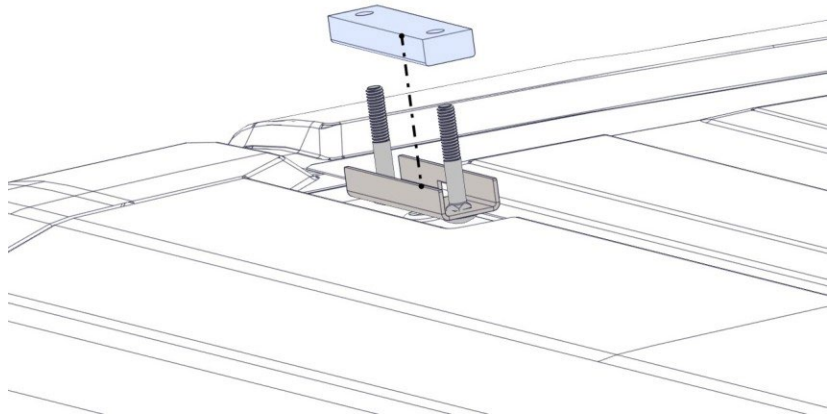

Step 5.
Install spacer 02P759 inside base brackets. Repeat for all 6 locations.

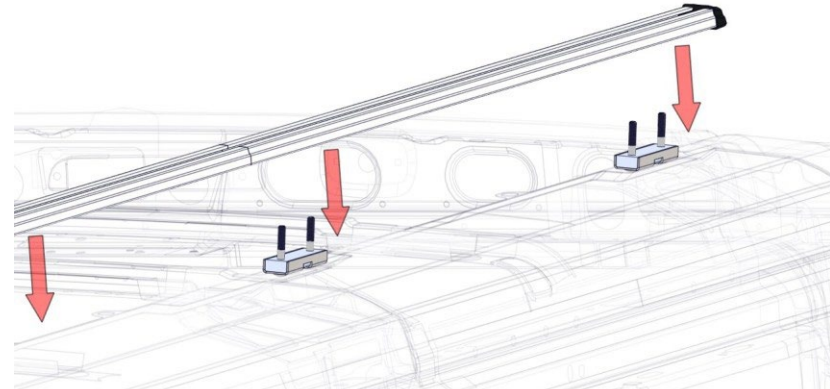

Step 6.
Place rails on top of vehicle and slide receiver blocks from Step 2 all the way forward.



Step 7.
Starting at the rear of the vehicle, use the 2nd hole as shown.

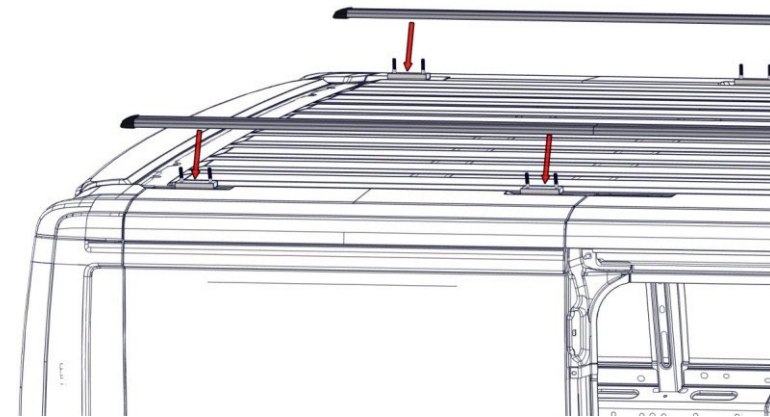

Step 7.
Place the rail on top of the base brackets.

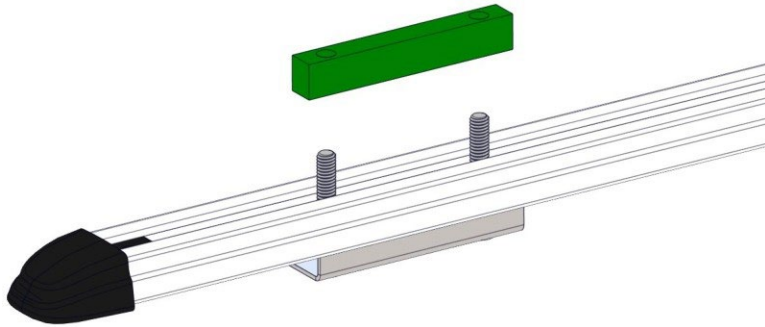

Step 8.
Install bolt spacers 02P790 as shown over the bolts inside the channel.

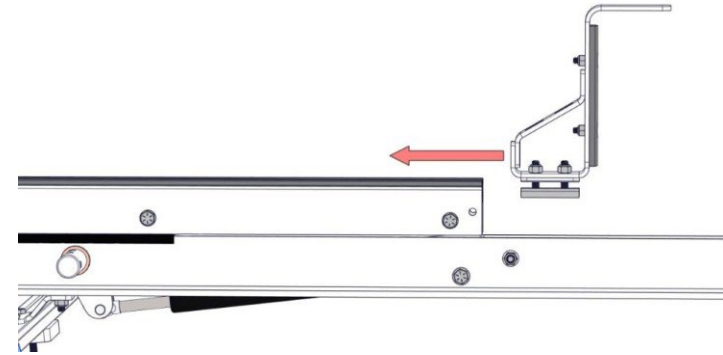

Step 9.
Slide ladder stop (02P664) tighten bolts using 9/16 socket or wrench.

IMPORTANT TO NOTE:

A BLUE sticker indicates the REAR Crossbows (02P325)



A GREEN sticker indicates the FRONT Crossbows (02675)

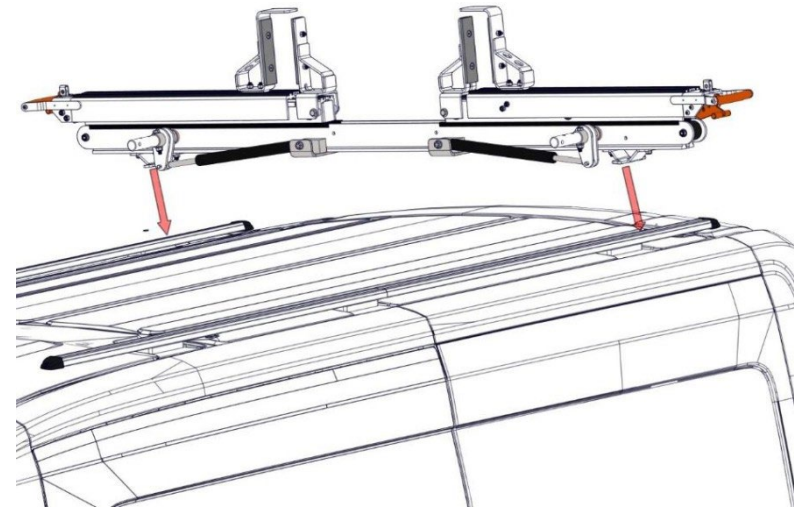

Step 10.
Lay rear crossbow across mounting rails

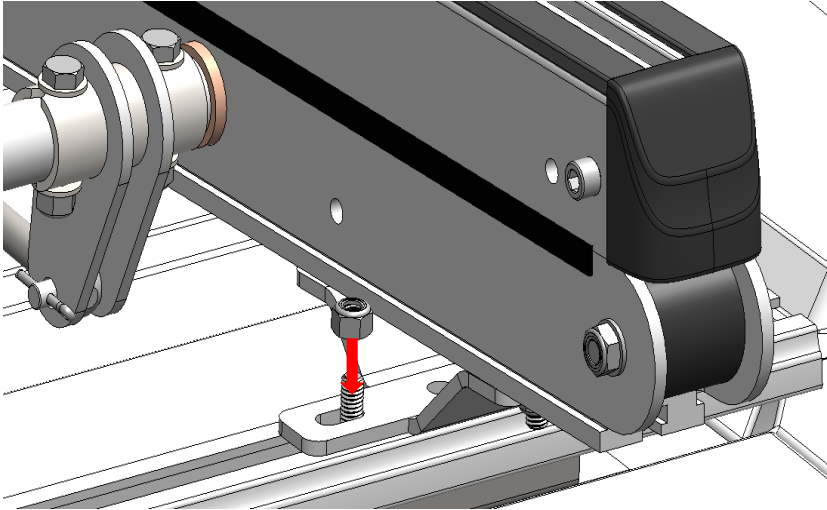

Step 11.
Install 5/16 SS nuts 02P168 (4) onto bolts as shown above. apply anti-seize to bolts; **DO NOT TIGHTEN**

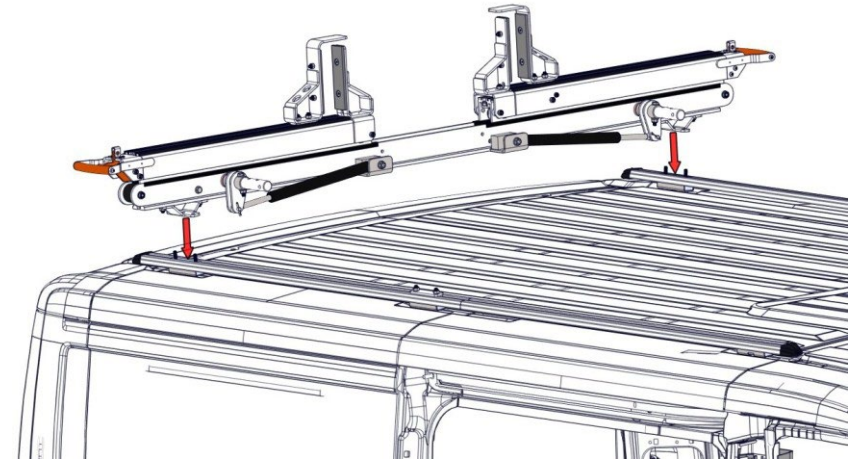

Step 12.
Install rear crossbow over base brackets and tighten 4 5/16" nuts (02P168)

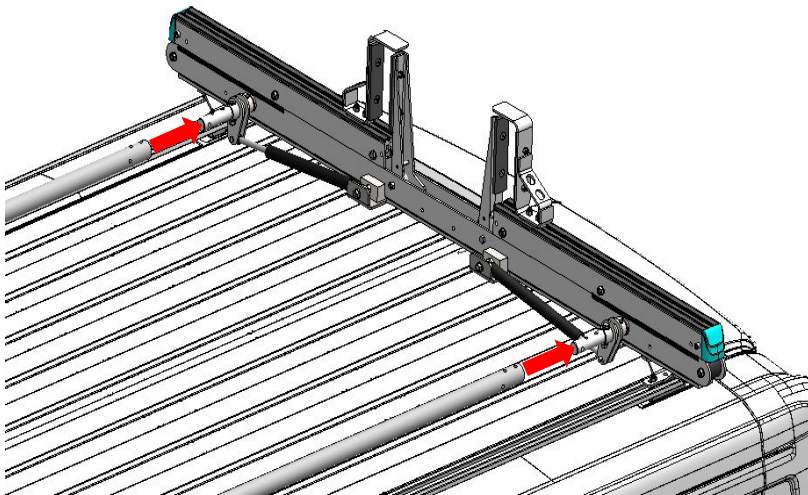

Step 13.
Install the connecting tube 02P328 & 02R035 into the rear crossbow assembly.

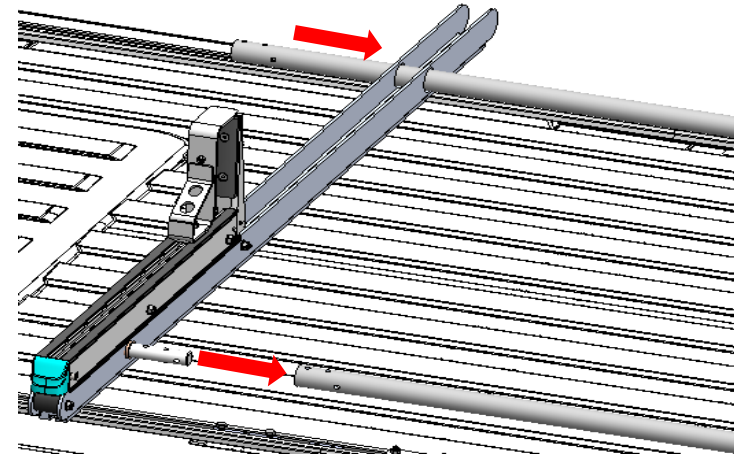

Step 14.
Install middle crossbow through the long connecting tube, and into the short

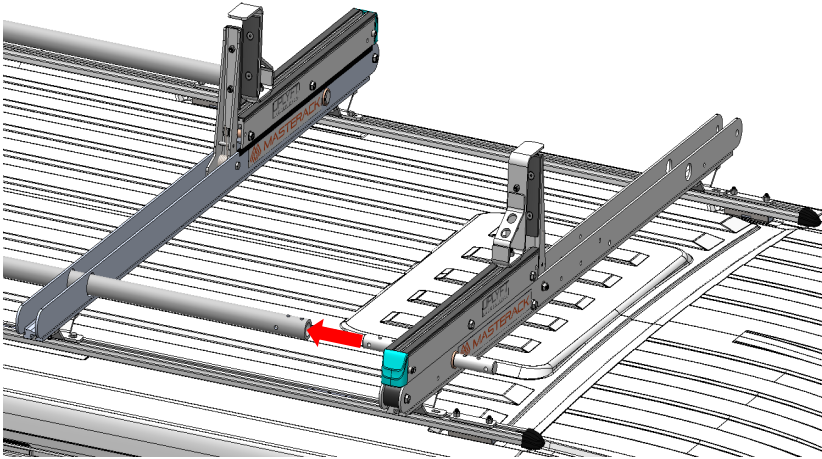

Step 15.
Set the front crossbow in place and slide into the connecting tube

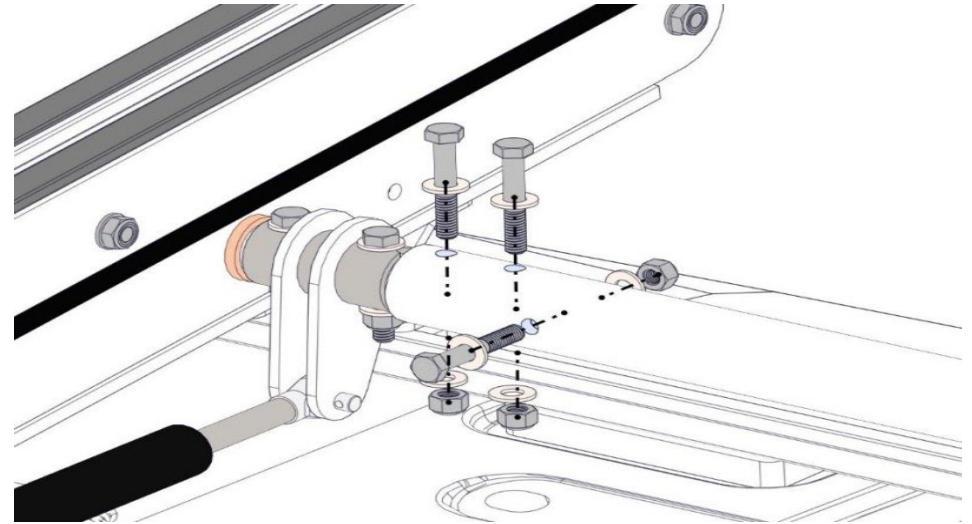

Step 16.
Using a 1/2" wrench and 1/2" impact wrench, install and tighten the connecting tube 5/16" x 2" bolts with the 5/16" washers and 5/16" lock nuts (02P168).

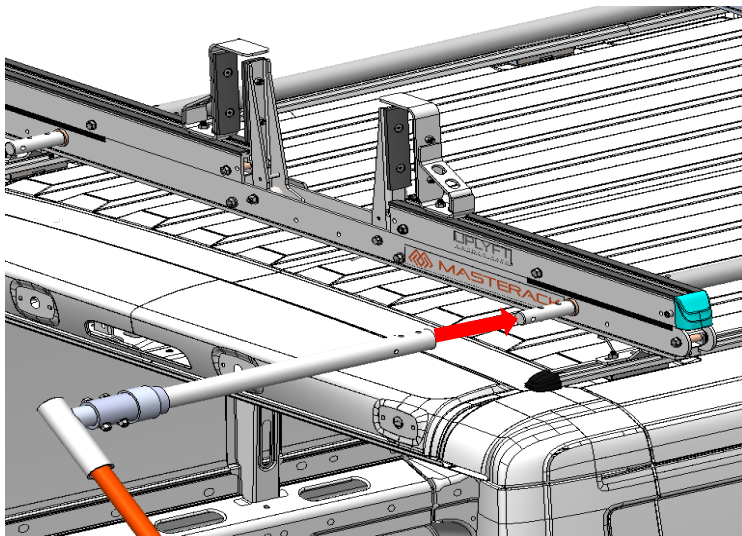

Step 17.
Install and tighten the handle assembly Using a 1/2" wrench and 1/2" impact wrench, 5/16" x 2" bolts with the 5/16" washers and 5/16" lock nuts 02P168.

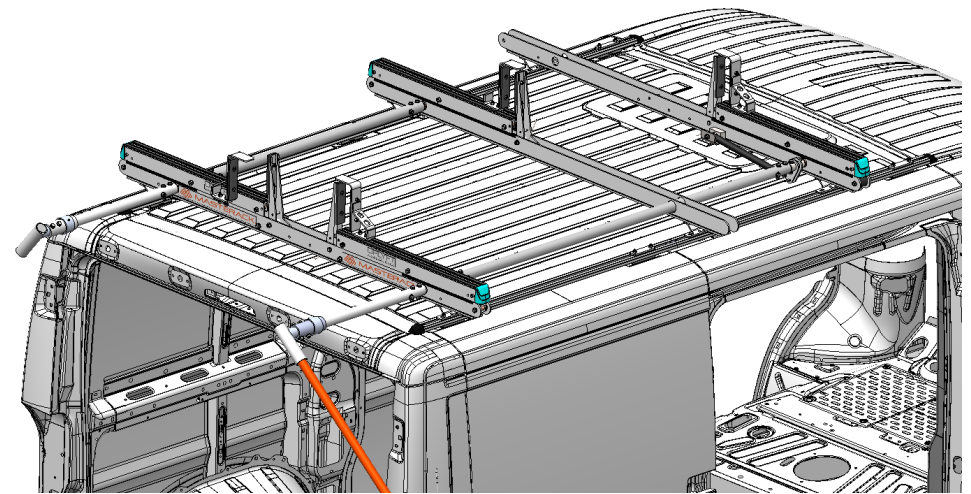

Step 18.
Assembly after installation