

TITLE: 02S813KP		
DOCUMENT #: WI-02S813KP	LABOR HOURS: 0.5	PRINT DATE: 8/29/24
REVISION: 3	PREPARED BY: J.LYBRAND	DATE PREPARED: 8/29/24
EFFECTIVE DATE: 8/29/24	REVIEWED BY: M.McCLELLAND	DATE REVIEWED: 8/29/24
FUNCTIONAL DEPARTMENT: ENGINEERING	APPROVED BY: M.McCLELLAND	DATE APPROVED: 8/29/24

STANDARD WARNINGS:

- READ WORK INSTRUCTIONS IN ENTIRETY BEFORE STARTING
- CHECK THAT YOU ARE PROPERLY CLEAR OF GAS TANK AND WIRES BEFORE DRILLING
- CONTACT ENGINEERING IF QUESTIONS ARISE OR DOCUMENT NEEDS TO BE UPDATED
- FOLLOW ALL LISTED OEM SYSTEM FUNCTIONALITY CHECKS AFTER INSTALL.

PART IDENTIFICATION / BOM:

PART #	DESCRIPTION	QTY
02S809	PART NP	1
02S810	BRKT PART NP	1
02S811	BRKT ATCH PART NP	4
02S812	HDW BAG PART NP	1
RM511458	SCREW HWHM 1/4-20X03/4 STL GR5	16
RM511433	SCREW HHC 1/4-20X 1-1/2 STL	11
RM520312	NUT ESH 1/4-20 STL ZP	27
RM541013	WASH 1/4 ZN GR2	27
RM518040	SCREW HHC M10X1.25X45 8.8 YL ZN	4
RM541232	WASHER FLAT 3/8X1 GR8 YL ZN	4

TOOLS REQUIRED:

- IMPACT or RATCHET
- 7/16" SOCKET
- 7/16" WRENCH
- 13MM SOCKET
- 14MM SOCKET
- T40 TORX
- LINE-UP PUNCH
- TORQUE WRENCH (ft.lbs. required)

PROCESS:

- Check the Vehicle Production Order (VPO) for VIN#, parts, and hardware. If something is not correct or missing let a lead or supervisor know as soon as possible. (Example: If the VIN# of the van does not match the VIN# on the VPO.) **NOTE: DO NOT DRILL OR INSTALL ANY ITEMS IN THE VAN UNTIL THE CORRECT PAPER WORK IS WITH THE VEHICLE.**
- Check the parts that are to be installed to make sure they are listed on the VPO.
- Once all items have been checked, proceed and prep for installation. Locate the above-listed items and the necessary tools to complete the installation.

Vehicle Preparation

- Slide the front seats as far forward as possible.
- Slide the second-row seats as far back as possible.
- Remove the four Front Seat Mount Trim by pushing down and pulling out on the sides.
- After the removal of the trim, stow with vehicle. Do not discard.

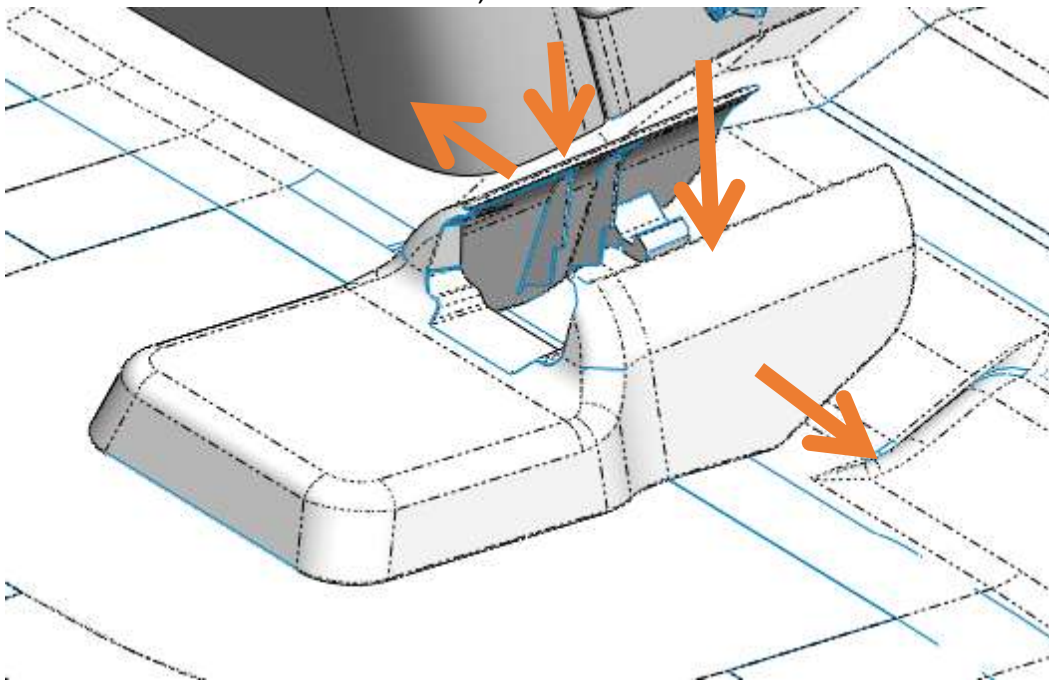

Figure 1: Removing the Seat Slide Trim by Squeezing and Pressing Down on the Sides

- Using the Impact and 13MM Socket, remove the four Front Seat Mount Bolts and set them aside.
- Next, using the T40 Torx, remove four of the second-row front seat bolts and set them aside.

Mounting the Partition Bracket

- After Vehicle Preparation is complete, insert the Partition Bracket (02S810) into the vehicle and place it on the second-row floorboard with the panel facing the rear and the bend opening facing the front. **Note: Assistance from a second person will be needed to set the Partition Brkt.**
- Place the front tabs of 02S810 inside of the Front Seat Slides as shown below.



Figure 2: Front Tabs in Seat Slide

- Using the Impact, 7/16" socket, and 7/16" wrench loosely attach the four Attachment Brackets (02S811) to the Partition Bracket in the corresponding locations where you removed the T40 Torx screws of the second-row seats using the following hardware per bracket:
 - 4 ea. – RM511458
 - 4 ea. – RM541013
 - 4 ea. – RM520312



Figure 3: Attachment Bracket w/ Hardware

- Reinstall the T40 Torx Seat Bolts removed in the *Vehicle Preparation* section by passing through the recently added Attachment Brackets and tighten
- Replace the 13MM Front Seat Bolts removed in the *Vehicle Preparation* section with (4) RM518040 and (4) RM541232 by passing through the recently added Partition Bracket. **Note:** Loosely install the (4) above mentioned bolts. Do not tighten any hardware at this time.



Figure 4: Replaced Seat Bolt

Mounting the Partition

- Carefully load the partition into the vehicle making sure the flat panel faces forward, and the structural members are exposed to the rear. **Note: Assistance from a second person will be needed to set the Partition Upper Panel and give support while the supporting hardware is installed.**
- Place the partition between the mounting tabs of the Partition Bracket.



Figure 5: Partition Set Between Bracket Mounting Tabs

- Loosely attach the partition to the partition bracket using the following per hole:
 - 1 ea. – RM511433
 - 1 ea. – RM541013
 - 1 ea. – RM520312
- **Note: the washers, RM541013, should be placed wherever there is a slot.**



Figure 6: Partition Mounted to Bracket w/ Hardware

- After the partition is completed installed, proceed in tightening all front and rear floor hardware, then tighten all other partition assembly hardware. **Note: Front seat bolts are to be tighten at 32ft. lbs.**
- Verify all bolts have been tightened.