

## Recommended Tools

Air or Hand Ratchet



7/16" Socket



7/16" Combo Wrench

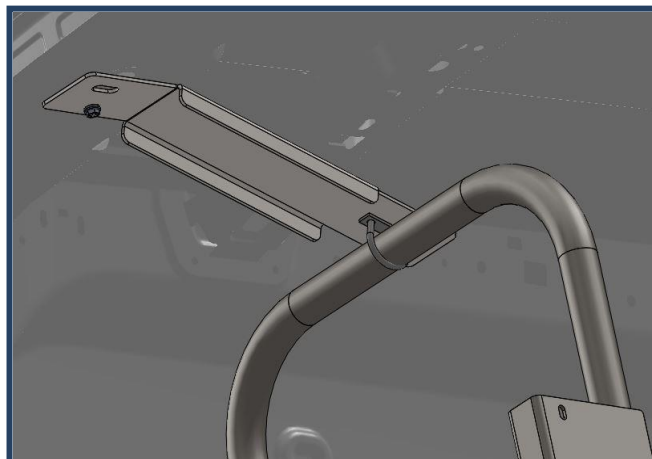
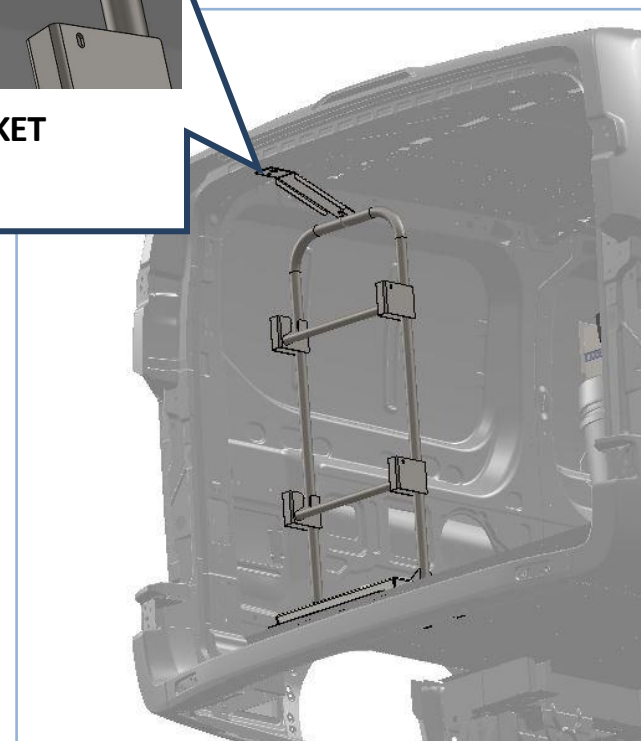

Torque Wrench

**CHARTER REEL BRACKET**
*02N541KP*

## Hardware

 1/4"-20  
 U BOLT w / MOUNTPLATE

 1/4-20X1-1/4 7/16  
 HWH SCREW

 1/4  
 WASHER SPLIT LOCK  
 GALV

 1/4-20X1-3/4  
 GRADE 5 HEX SCREW

 1/4-20  
 PRE-BULB PLUSNUT

PLUSNUT TOOL

**Review this document to ensure that all parts and hardware are included in the package, before installation. In the event that parts are missing please contact Masterack @ 1-800-222-8785, to re-order missing parts.**

**BEFORE INSTALLATION PLEASE REVIEW THIS ENTIRE DOCUMENT, UNTIL YOU ARE COMPLETELY FAMILIAR WITH ALL STEPS BEFORE BEGINNING. A "PRACTICE RUN" OF THESE STEPS / PROCEDURES MAY BE HELPFUL TO ASSIST YOU IN FAMILIARIZING YOURSELF THOROUGHLY, AND AVOIDING COSTLY ERRORS.**

**SECURING REEL BRACKET**

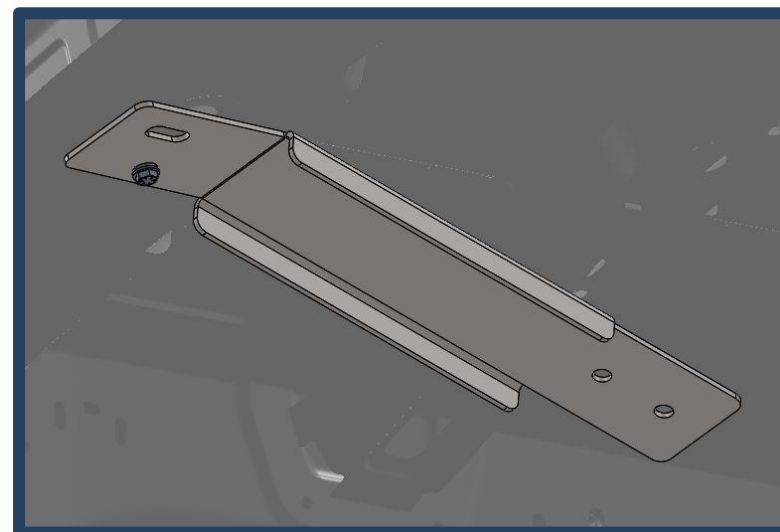
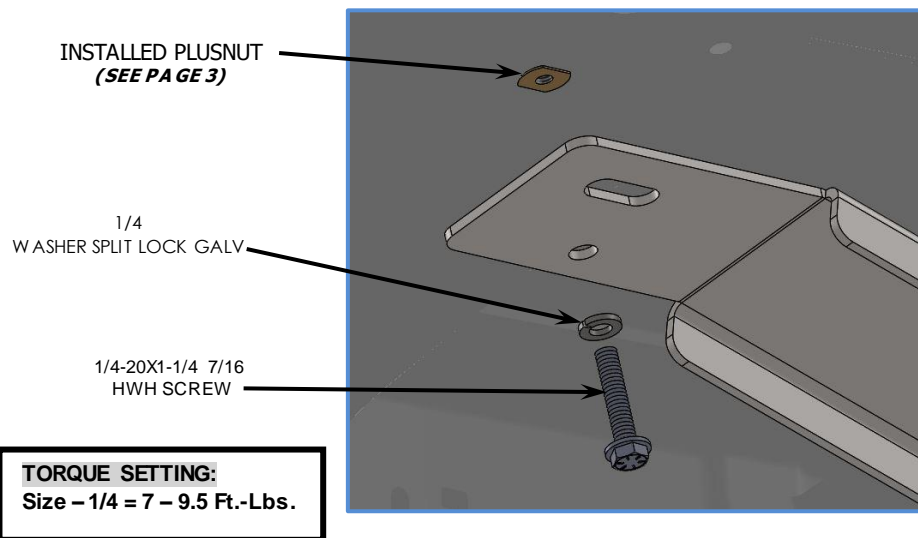

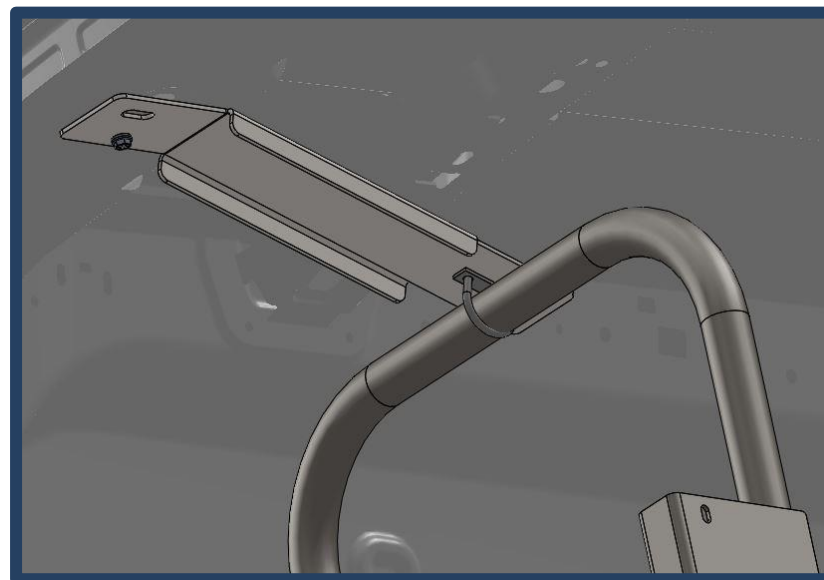
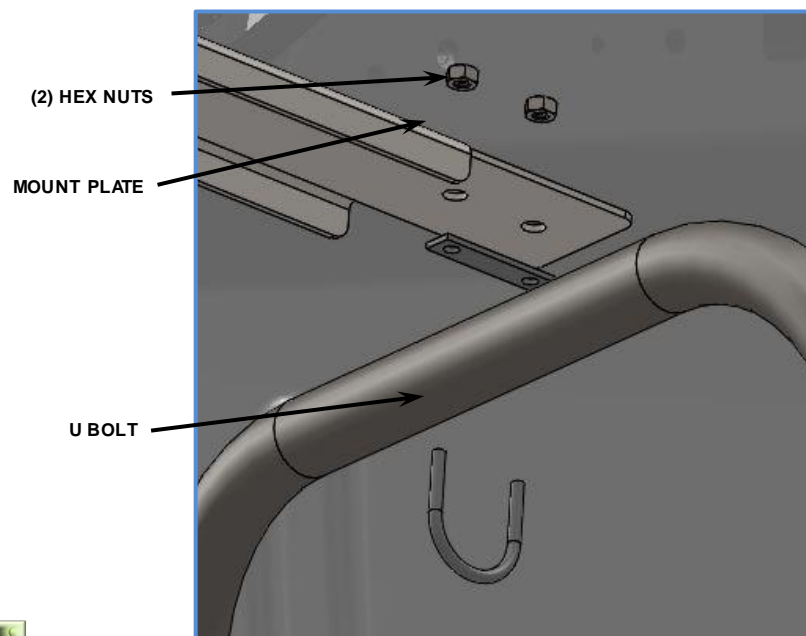

**ATTACHING U BOLT w/ MOUNT PLATE and SECURING REEL HOLDER**



**INSERTING PLUSNUTS**

**BEFORE DRILLING**

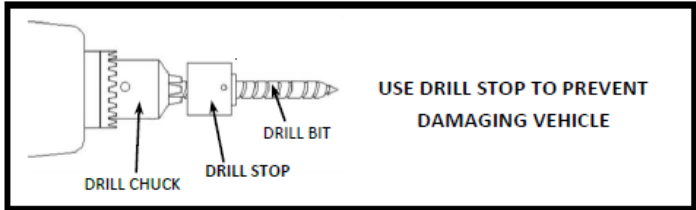
**STOP** CHECK ALL MOUNTING LOCATIONS TO PREVENT PENETRATING GAS LINES, GAS TANKS, BRAKE LINES, WIRING OR ANY OTHER STRUCTURE OF VEHICLE **STOP**

The Plusnut® is pre-bulbed for easy installation

1



The Plusnut® is pre-assembled with hex cap and hex bolt. Then it is inserted into a pre-drilled hole

2

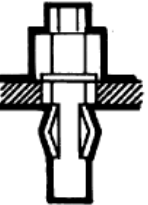

As the bolt is tightened, the Plusnut® upsets and provides outstanding blind fastening holding power

3



C-500 tool tightens bolt thru hex head cap into Plusnut® A ratchet, open-end or closed –end wrench can be used.

4



Fully upset Plusnut® provides a reliable nut plate for fastening.

5

## 3 Year / 36,000 Mile Limited Warranty

MASTERACK® commercial van and pickup equipment is warranted to be from defects in material and workmanship, under normal use and service for a period of one (1) year from date of purchase. Factory installations, and products installed in new vehicles by an authorized MASTERACK® installer are warranted for (3) years or 36,000 miles (60,000 KM), whichever comes first. **This warranty covers only repairs, or at MASTERACKS' discretion, replacement to correct any defects related to materials and workmanship.**

### This warranty does not apply to:

- Additions, alterations, or installations made by persons including dealers, other than MASTERACK® and its authorized distributors, made in accordance with MASTERACK® specifications and / or instructions, nor to defects arising out of attribute to such additions, alterations or installations.
- Defects attributable to abuse or misuse of the product, misapplication, negligent accident, modification or tampering.
- Damage resulting from failure to promptly notify and comply with the instructions of the dealer or manufacturer about defects when noted.
- Any incidental or consequential damages connected with a defect, either while under warranty or afterward, including the cost of a rental truck and / or loss or revenue.

**THE WARRANTY IS THE ONLY WARRANTY APPLICABLE TO A MASTERACK PRODUCT PURCHASE. ALL OTHER WARRANTIES, EXPRESSED OR IMPLIED, INCLUDING BUT NOT LIMITED TO, THE IMPLIED WARRANTIES OR MERCHANTABILITY AND FITNESS FOR A PARTICULAR PURPOSE ARE DISCLAIMED. MASTERACK® AND ITS SUBSIDIARIES, SHALL NOT BE LIABLE FOR ANY INCIDENTAL OR CONSEQUENTIAL DAMAGES ARISING OUT OF ANY BREACH OF THIS WARRANTY, NOR SHALL THE DAMAGES EXCEED THE RETURN AMOUNT OF THE PURCHASE PRICE PAID BY THE ORIGINAL PURCHASER.**

Warranty claims must be submitted to either your sales representative or a customer service representative at **1-800-222-8785**. The vehicle must be delivered to the original MASTERACK® authorized dealer for inspection and any warranty service. Any warranty service to be performed by a source other than MASTERACK® location or an approved MASTERACK® distributor must be authorized in advance of the repairs by the MASTERACK® Warranty Administrator and a purchase order issued by MASTERACK® in advance or repairs for the authorized repairs.